

USER GUIDE MixRite TF-10

Tefen is pleased to welcome you as a new customer.

Please read this manual carefully before using the product and follow the safety guidelines.

For additional information on our MixRite proportional dosing pumps please visit our website - <https://tefentech.com/downloads>

or Scan the QR code below



SAFETY



Warning:

During operation, the operator must stay in front of the MixRite pump and wear protective eyewear, clothing and gloves.

Be extremely careful in the presence of hazardous substances (e.g. corrosives, toxins, solvents, acids, caustics, flammable, etc.). The user must adhere to the recommendations given by the chemical product manufacturer.



Caution:

Use proper tools. DO NOT USE METALLIC TOOLS. Use only plastic connectors.

It is the responsibility of the owner/operator to make sure water flow and pressure do not exceed the MixRite specifications.

Before applying any aggressive chemicals, please consult your distributor to confirm compatibility with the dosing pump.

When connecting a MixRite either to the public water supply or to its own water source, you must respect the regulations in force concerning protection of the source i.e. backflow prevention, etc.



Important notes:

Ensure water flow is according to the arrows on the unit.

Use 120 mesh-130 micron filter. For water with high particle content, use 250 mesh - 60 micron filter depending on your water quality.

It is recommended to place an anti-siphon valve on the downstream side of the dosing pump in installations in which there is a risk of siphoning.

Do not operate your MixRite when the additive tank is empty.

For installations subject to water hammer/ excessive flow, a protection device such as a check valve or union ball check must be fitted (pressure/flow control system).

SYSTEM OVERVIEW

MixRite TF-10

Water Pressure

1-8 bar
(14.5-116 psi)

Flow Rate

0.1-10 m³/h
(0.44-45 GPM)

Working Temp.

4-40° C
(39.2-104° F)

Coupling

1.5" or 50 mm

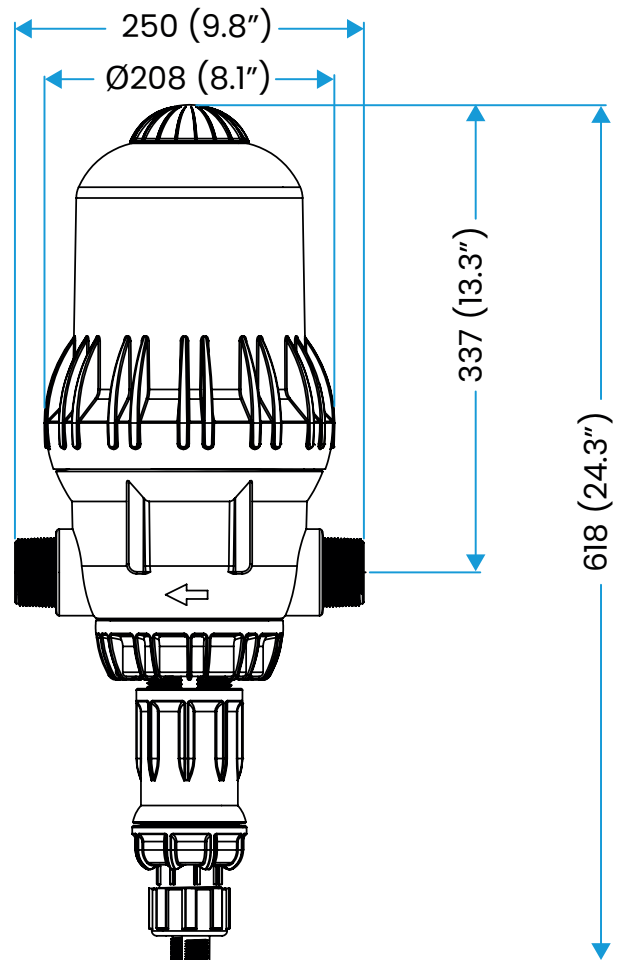

L (Height)	
On/Off	Air Release
Max. 760 (29.9")	660 (26")
Max. 720 (28.34")	625 (24.6")

1. INSTALLATION



Note: MixRite TF-10 can be installed on a bypass line as well.

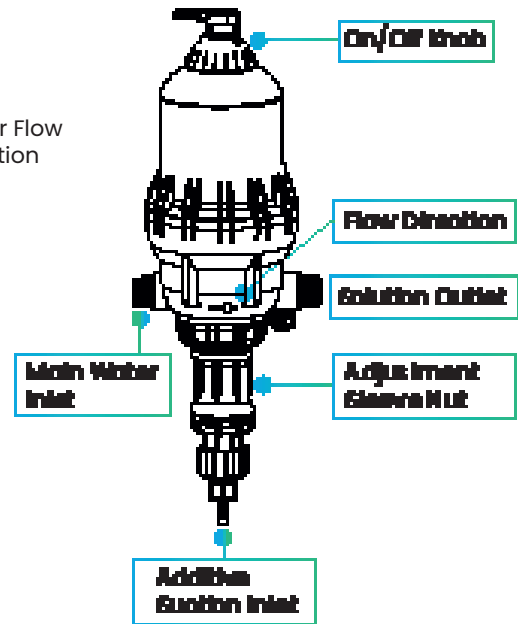
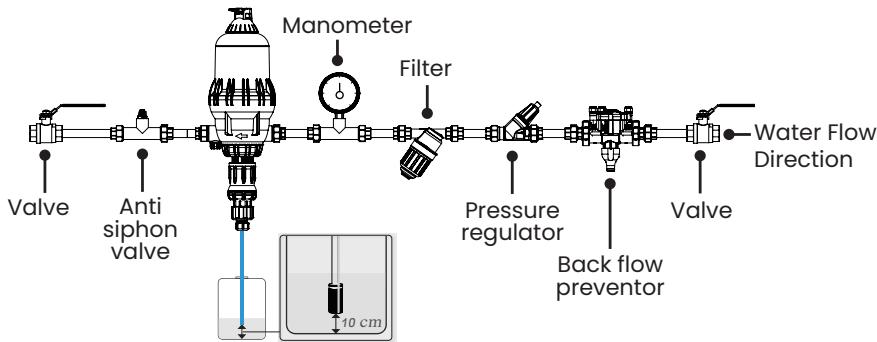

Fig. 2 - Installation illustration



Important!

If the water line is higher than the MixRite itself, there is a possible risk of water and additive flowing back through the MixRite (see Fig. 2). In such a case, installing a non-return valve downstream is necessary.

The strainer must be suspended at least 10 cm (4") above the bottom of the additive tank to avoid sucking up the insoluble particles that may damage the pump assembly.
Do not put the strainer on the ground.

Water hammer/excessive flow:

For installations subject to water hammer, a protection device such as a check valve or union ball check must be fitted (pressure/flow control system).

For automatic installations, slow opening and closing solenoid valves are preferable.

In an installation where the MixRite serves several sectors, the closing of one sector and the opening of another sector must be done at the same time (simultaneous operation of the solenoid valves).

2. INSTALLATION

1 Mounting MixRite TF

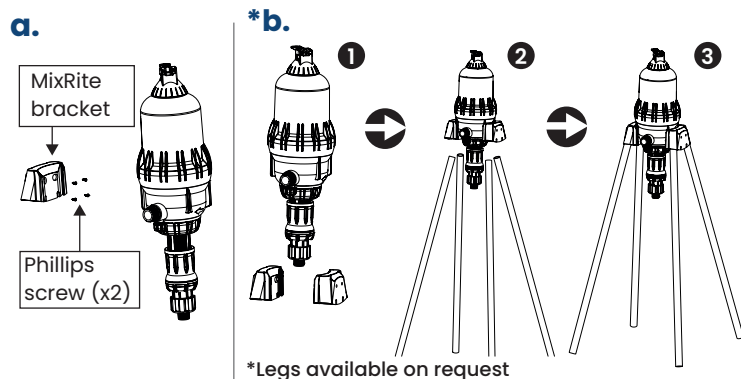

2 Connecting suction tube

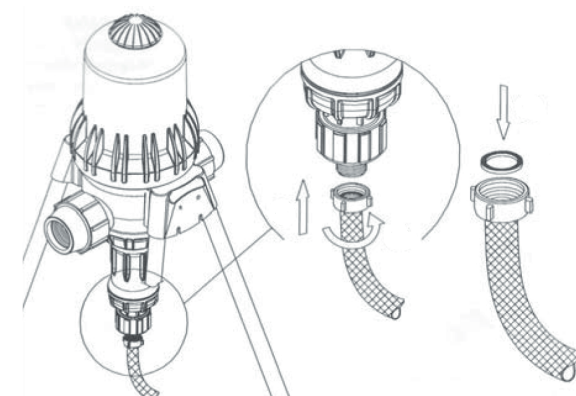

3 Adjusting dosage

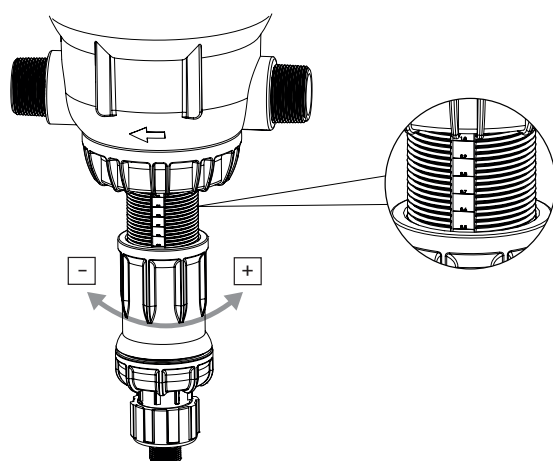

4 MixRite cover options

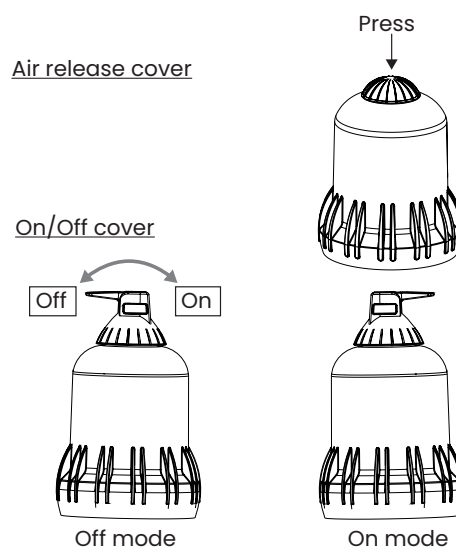

3. MAINTENANCE



Important!

To maintain the dosing pump in good condition, it is advisable to operate the pump with suction of clean water after each use.

Regular yearly maintenance will help extend the lifespan of your MixRite dosing pump. In addition, kit seals need to be replaced every year.

Regularly clean the water filter at the pump inlet and the additive suction filter.

If the pump is planned to be out of use for a long period of time, operate the pump for a few minutes with the suction tube immersed in a tank with clean water to remove additive residues from the pump, preventing them solidifying in the pump.

If there is a fear of frost, and the temperature falling below 4°C (39°F), empty the water from the pump. To do this, close the entry and exit valves securely. Open and dismantle record nut that connects the suction pipe. Press the backflow prevention valve using a finger or a thin rod, allowing all the water that has collected in the pump to drain out while pressing the air-release valve at the top of the pump.

It is advisable to carry out the maintenance of the pump body whenever soluble products are used. To carry out the maintenance, remove the pump body and wash it thoroughly with plenty of clean water. When finished and before reassembly onto the motor body, lubricate the seal with silicone.

An air inlet, impurity or chemical damage to a seal can interrupt the dosing function. It is recommended to periodically check that the solution is being correctly drawn up into the MixRite.

Change the suction tube as soon as it seems damaged by the chemical.

It is advised to relieve the pressure after use.

3.1 Rinsing and Cleaning the Unit

Rinsing of the MixRite is required when changing chemicals and before handling the MixRite, to avoid any contact with the chemical.

Rinse the MixRite as follows:

1. Rinse the unit by pumping clean water from the additive container.
2. Wash the external surface of the unit with clean water.

3.2 Cleaning and Refitting the Suction Check Valve

Before removing Suction Check Valve, turn off the water supply and allow the pressure to drop to zero.

Remove Suction Check Valve.

Rinse parts of Suction Check Valve with clean water, re-assemble them and ensure that the spring is in good working condition.

Re-assemble Suction Check Valve in the reverse order.

3.3 Action Frequency

Action	Frequency
General Check	After each use
Cleaning Cycle	Yearly
Replace Seals	Yearly
Replace Other Components	As needed

4. TROUBLESHOOTING

Subject	Check	Solution
The pump isn't working	Direction of arrows on the pump is the same as water flow.	Install the pump so that the arrows point in direction of water flow
	Inlet and outlet valves are open.	Open the valve.
	Inlet filter is not clogged.	Clean the filter.
	Line's water pressure.	Make sure there is water pressure in the line – check the system input filter and make sure it is clean.
	Springs are not broken.	Replace the motor.
	Cylinder is not scratched.	Replace cylinder.
	Piston seals are not damaged.	Replace the seals.
	Bypass installation* pump test at low pressure.	Disconnect the water outlet hose from the outlet, by installing a bypass make sure there is no water returning to the pump. If the pump is working check the ΔP – as described in the item below.
Bypass installation* make sure the pressure difference.	The water pressure at the outlet of the pump is equal to or greater than the water pressure at the main line.	
The pump stopped working	There is no water flow at the appropriate pressure. Open the main valve. Open the nut locking the motor cover, remove the motor cover, and remove the mechanism. Check if the motor seals are defective.	Replace the motor seals.
	Check if the springs are broken.	Replace the motor.
	Check if one of the parts of the mechanism is broken.	Replace the motor.

Subject	Check	Solution
MixRite does not draw additive.	The suction filter is blocked.	Clean the filter.
	Dismantle the pump unit and check if the suction seal is defective.	Replace the suction seal.
	The non-return valve is defective.	Replace the non-return valve.
MixRite makes scratching noises.	Check if there is liquid in the additive container.	Add liquid to the container.
	Check if the suction pipe is immersed and not folded.	Straighten or change the pipe.
	Check suction filter to see if it is blocked and if it is immersed in the additive tank.	Clean and rinse suction filter. Fill liquid into tank to cover filter.
Water flowing back into additive container.	Check valve.	Clean or replace the check valve.

5. SPARE PARTS

5.1 MIXRITE TF-10 STD Model



Cat. No.	Kit # %	Seal	Suction Piston	Suction Tube	Check Valve	Cylinder	Motor
280801X00XX 280901X00XX	0.1%-1%	35100000001	35100000019	36000000025	35200000058	35100000009	35100000006
280802X00XX 280902X00XX 281002X00XX	0.2%-2%	35100000002	35100000020	36000000025	35200000058	35100000011	35100000006
280805X00XX 280905X00XX 281005X00XX	1%-5%	35100000005	35100000021	36000000025	35200000058	35100000012	35100000006
Recommended sets per dosing pump		100/100	5/100	10/100	10/100	10/100	5/100

5.2 MIXRITE TF-10 CL Model



Cat. No.	Kit # %	Seal	Suction Piston	Suction Tube	Check Valve	Cylinder	Motor
280801XCLXX 280901XCLXX	0.1%-1%	35100000001	35100000019	36000000025	35200000060	35100000050	35100000053
280802XCLXX 280902XCLXX 281002XCLXX	0.2%-2%	35100000002	35100000020	36000000025	35200000060	35100000051	35100000053
280805XCLXX 280905XCLXX 281005XCLXX	1%-5%	35100000005	35100000021	36000000025	35200000060	35100000052	35100000053
Recommended sets per dosing pump		100/100	5/100	10/100	10/100	10/100	5/100



5.3 MIXRITE TF-10 CLPO Model



Cat. No.	Kit # %	Seal	Suction Piston	Suction Tube	Check Valve	Cylinder	Motor
280801XCLPO 280901XCLPO	0.1%-1%	35100000001	35100000019	36000000025	35200000058	35100000009	35100000056
280802XCLPO 280902XCLPO 281002XCLPO	0.2%-2%	35100000002	35100000020	36000000025	35200000058	35100000011	35100000056
280805XCLPO 280905XCLPO 281005XCLPO	1%-5%	35100000005	35100000021	36000000025	35200000058	35100000012	35100000056
Recommended sets per dosing pump		100/100	5/100	10/100	10/100	10/100	5/100

5.4 MIXRITE TF-10 Model - Cover



MixRite TF-5 Model		Air Release	On/Off	Electric DC	Electric AC	Hydraulic
STD		35100000054	35100000022	35100000017	35100000018	35100000016
CL		35100000058	35100000037			
CLPO			35100000023			
Recommended sets per dosing pump		5/100	5/100	5/100	5/100	5/100

6. SPECIFICATIONS

Pressure Loss

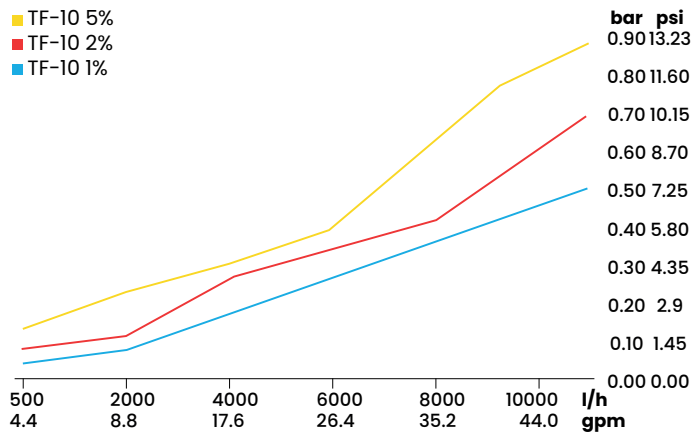

Max. injection rate/h

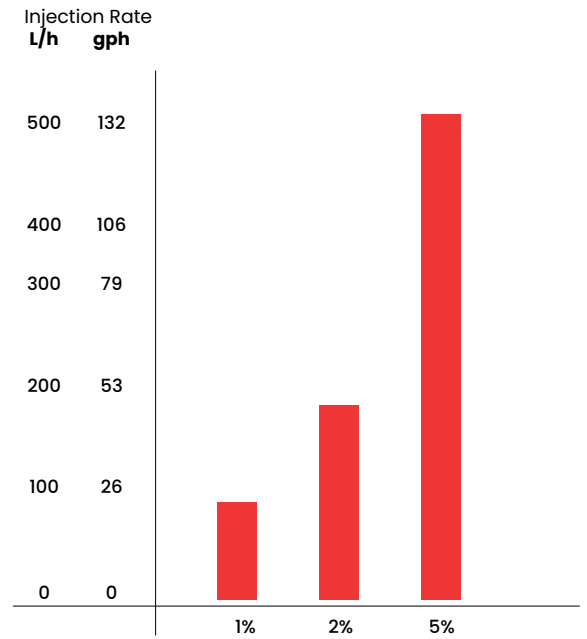

7. LIMITED WARRANTY

Tefen Flow and Dosing Technologies Ltd. (“Tefen”) will replace all parts shown to be defective in material or workmanship during a period of twelve months from the date of purchase by the original purchaser (“Warranty Period”). Warranty shall be limited to Warranty Period and shall not be extended in any event. To obtain warranty replacement of a part, the MixRite must be returned with original proof of purchase receipt to Tefen or authorized distributor and thereafter recognized as defective after examination by the technical services of the manufacturer or distributor.

The MixRite must be flushed of any chemical and sent to the manufacturer or distributor prepaid but will be returned free of charge once repairs are made if found to be covered by the warranty.

This warranty only covers circumstances where the part has failed due to defects caused by the manufacturing process. This warranty is invalid if the defects are found to be due to the product’s misuse, inappropriate use of tools, negligence, changes and/or alterations made in the Product not by Tefen, combination and/or use with other products not manufactured by Tefen, lack of maintenance and/or defective installation or environmental accidents or corrosion by foreign bodies and liquids found within or in proximity to the MixRite.

The seals and “O” rings are not covered under warranty, nor is damage to the MixRite caused by water impurities such as sand. A filter (200 Mesh) must be used in front of the unit for this warranty to be valid.

Tefen declines any responsibility if the MixRite is not used in compliance with the operating instructions and tolerances as indicated herein.

There are no warranties, express or implied, which will extend beyond those described above.

TEFEN OR AUTHORIZED DISTRIBUTOR SHALL NOT BE LIABLE FOR ANY LOSS OF USE, SALES OR PROFIT OR FOR ANY INDIRECT, CONSEQUENTIAL OR INCIDENTAL DAMAGES CAUSED BY OR SUFFERED AS A RESULT OF THE SALE OR USE OF THE PRODUCT AND SHALL BE LIMITED TO THE CONSIDERATION ACTUALLY PAID BY YOU FOR THE PRODUCT. This warranty is personal, and you may not assign, transfer, sell, indorse, pledge its rights under this warranty to any third party without Tefen’s prior written consent.

Any dispute arising in connection with this warranty shall be referred to the competent court in Tel Aviv Israel, which shall have exclusive jurisdiction in relation to all matters which may arise out of or in connection with this warranty. The provisions of the substantive law prevailing in Israel shall govern this warranty.